

# MOUNTING SUPPORT & GUIDE BRACKETS

RIGHT: This photo shows the position of the gantry support and guide brackets. These brackets come unpainted, but are colored yellow here for clarity. The aluminum brackets that hold the gantry sections together, and the motor mount brackets are covered elsewhere in these instructions.

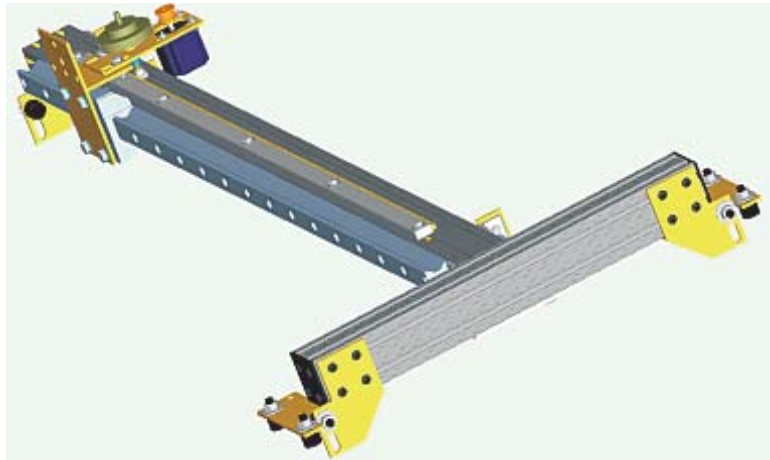

The brackets are secured to the grooves in the aluminum extrusions with the supplied 5/16" x 18 x 5/8" button head cap screws and t-nuts.

After the brackets are in place, the 1" diameter cam followers are mounted.

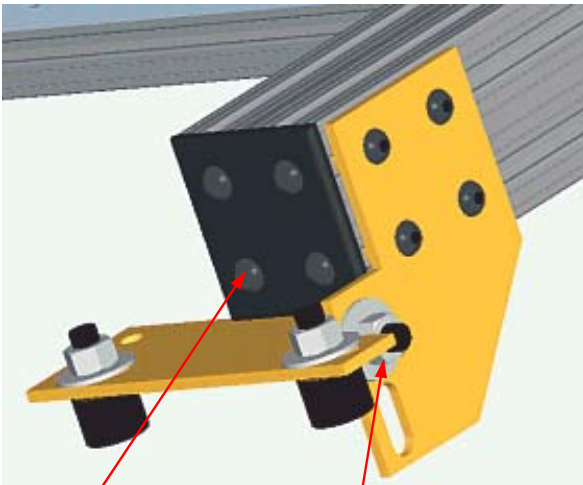

Black plastic end caps are secured with 4 of the supplied plastic push fasteners.

Cam follower that supports the gantry is secured here.

Cam follower studs are secured in these two slots as shown here.

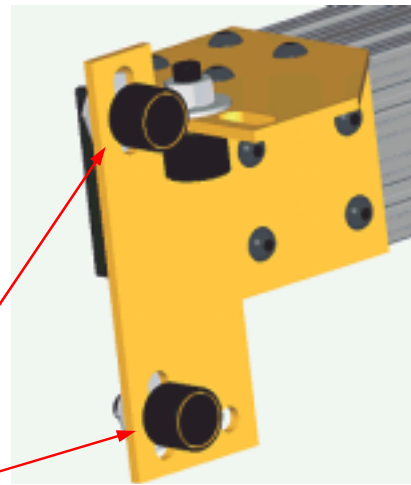

Button head cap screws fit 4 threaded holes in one end of the long extrusion.

The threaded stud of the cam follower is secured in the hole above the slot in the bracket.

The slots are only used when the optional automated Z axis for routing is installed.

